

## SNV-12 Signal-and-Noise Voter Comparator



The SNV-12 modular receiver voting system uses individual Digital Signal Processing (DSP) channels to measure the quality of received signal for fast and accurate determination of the best signal. The SNV-12 chassis accommodates from 2 to 12 receiver Site Voter Modules and interfaces easily with standard dispatch consoles.

### Benefits

- Detects and generates EIA key-tones in addition to hard PTT.
- Can repeat voted audio.
- Local control plus IP and serial remote control.
- Automatic and manual transmit steering capability.
- Digital delay compensates for differences in link paths.
- System expansion to 36 sites by daisy-chaining multiple SNV-12s.
- 5.25" high by 19" wide rack-mount modular card-cage package.

### Overview

The SNV-12 uses Digital Signal Processors to continuously monitor multiple remote sites and select the receiver with the best signal quality. One application is a two-way radio application where mobiles and portables can hear a repeater, but due to lower transmit power and/or antenna placement, the repeater can't hear the mobiles and portables. Remote receivers can be positioned in the communications deadspots, with audio from each receiver linked to the voter via microwave, landline, twisted pair, or fiber optics. The voter will select the best quality signal from all remote receivers and forward this signal to the repeater for rebroadcast; providing greater talk back range for radios.

### DSP Voting

The Site Voter Module (SVM) uses a spectral approach to continuously measure the

noise or Signal-to-Noise Ratio (SNR) of the audio signal from each receiver site. The signal and noise amplitudes are measured by JPS proprietary speech detection and measurement algorithms. Each SVM continuously measures its receiver signal and calculates a Signal Quality Number in 31 discrete steps. The SNV-12 monitors all SVMs and votes the site with the best Signal Quality Number. This ensures the best site is voted even if the received signal is emanating from a moving vehicle between buildings or between remote voting receiver sites.

The SNV-12 parameters also allow the voter to be set to lock on the initially voted site, which is important in systems where no voted site transitions are desired during any individual field transmission.

The voting process is initiated whenever any receiver

unsquelches. This is signalled either by loss of pilot tone or by a hardwired receiver signal (COR output or multiplexer E-lead); individually configurable on each SVM. The SNV-12 will accept pilot tone frequencies of either 1950 or 2175 Hz, configured by dip-switch.

### Transmit Steering

In automatic transmit steering applications, the transmitter associated with the currently voted receiver is used for a reply mobile or portable in the field that made the initial call, as well as to any nearby radios. In manually controlled applications the dispatcher decides which transmitter site to use for a reply. The voter also groups multiple voting receivers around individual remote transmitters. Tone Keying and Repeat Mode are also provided within this function.

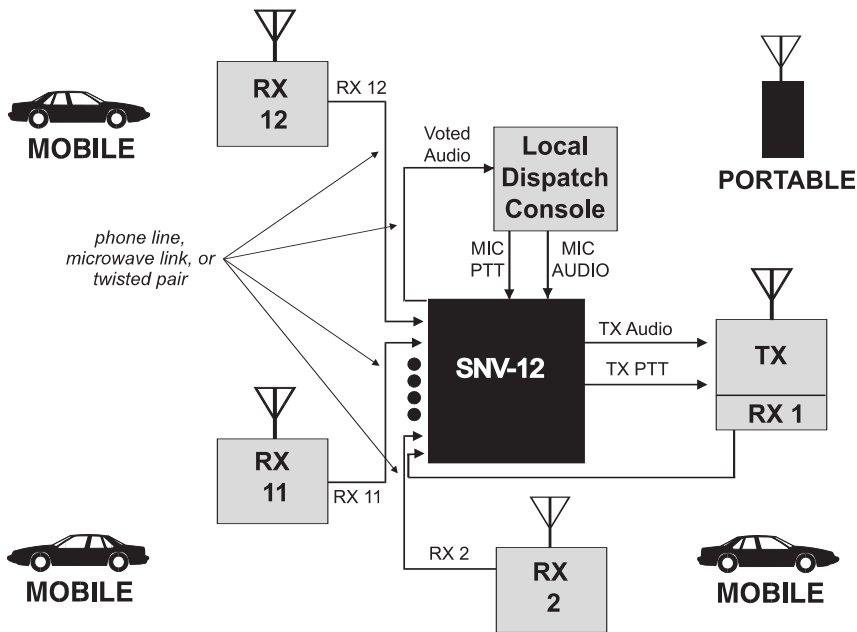

Diagram: Repeater System using the SNV-12 Voter with 12 Receivers.

**Site Voter Module Audio Inputs**

**Radio RX Input:** Balanced 600 Ohms or 10k Ohms, unbalanced 10k Ohms.

**Input Level:** -30 to +10 dBm, adjustable.

**Unsquench Indications:** 2175Hz pilot tone; 1950 Hz pilot tone; E-Lead input. Pilot tone generator accessory, PTG-10, enable use of any receiver with a COR output.

**Voting Audio Output**

**Output:** Balanced 600 Ohms.

**Output Level:** -20 to +11 dBm, adjustable.

**Frequency Response:** 200 to 3200 Hz± 2dB. (300 to 3000 Hz ± 1dB).

**Keying:** EIA Keytones or E&M.

**Absolute Output Delay:** Less than 10msec.

**Voting Comparator**

**Switching Time Between Sites:** Less than 1 msec.

**Unselected Output Rejection:** Greater than 60 dBm.

**Voting Thresholds:** 31 steps.

**General/Environmental**

**Site Voter Module Front Panel (SVM-2):** Select/Normal/Disable Switch, Voted LED, Unsquenced LED, TX LED, TX Select LED, Fault LED, Input level test point and control.

**Console Interface Front Panel (CIM-2A):** Speaker Off/Rx/Rx and Tx, Volume control, Norm audio level LED, Peak audio level LED, Fault LED, Remote LED.

**Serial Port :** RS-232 DCE connector (female DB9). Baud rates: 300 - 57,600

**Network Interface :** RJ-45 Connector; 10/100 Base-T Ethernet. T1 5409A DSP, Ethernet (built in webpage), Telnet.

**AC Input Power :** 115 or 230 VAC ± 15%, 47-63 Hz, 130 VA maximum when "fully loaded".

**DC Input Power :** +11 to +15 VDC @5A nominal.

**Size :** 5.25"H x 19"W x 11"D (13.3 x 48.3 x 28 cm).

**Temperature :** Operating: -20 to +60 degrees C. Storage: -40 to +85 degrees C.

**Certifications :** TUV, FCC Part 15. Class A.

Raytheon Company  
**JPS Communications**  
 5800 Departure Drive  
 Raleigh, NC 27616  
 sales@jps.com

www.raytheon.com/JPS

**Raytheon**

Customer Success Is Our Mission